



Technical data sheet

Marine diesel engine

D2676LE487

04.07.2022

(Version 1)

Performance data

Rated power	290	kW
Rated power	394	PS
Speed	1800	rpm
Bore/Stroke	126/166	mm
Displacement	12,42	liter
Rated torque	1538	Nm
Maximum torque	1760	Nm
at speed	1300-1600	rpm
Compression ratio [ε]	18,0	:1
Mean effective pressure	15,57	bar
Mean piston speed	9,96	m/s

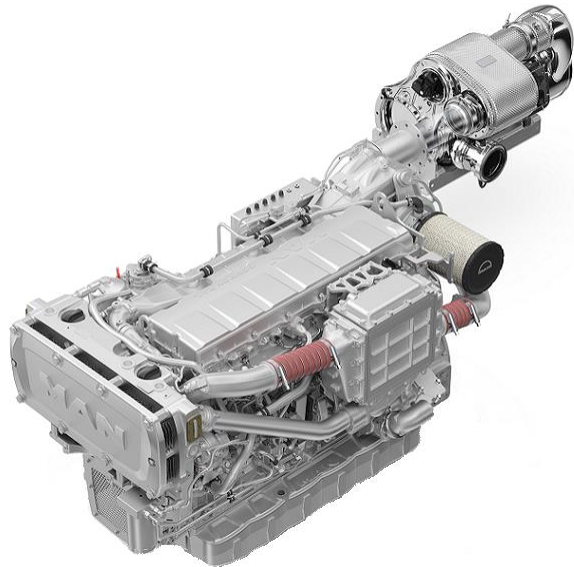

The engine illustrated may not entirely be identical to production standard engine

Consumption data ²

Specific fuel consumption ¹	201	g/kWh
Absolute fuel consumption ¹	69	l/h
Lowest fuel consumption ³	200	g/kWh
Absolute urea consumption ¹	4	l/h

Engine description

Application	Main propulsion diesel for ships with fixed pitch propeller or variable pitch propeller
Operation profile	Unlimited operating hours per year at a maximum of 100 % of time at full load
Construction	Four-stroke diesel with exhaust after-treatment system, direct injection, SAE 1 flywheel housing
Cylinders	6 cylinders in line, wet replaceable cylinder liners
Air system	Single-stage turbocharger with charge air intercooler and wastegate
Cooling system	Seawater cooled by rubber impeller pump or two-circuit-cooling system for hull cooling
Oil system	Force-feed lubrication by gear pump, lubricating oil cooler in cooling water circuit of the engine
Fuel system	Common Rail injection system with EDC17 control, fuel according to DIN EN 590, GTL/HVO
Auxiliary PTO	PTO for hydraulic pump 16 cm ²
Alternator	Three-phase generator with rectifier and transistorized governor, 28V, 120A
Starting system	Solenoid-operated electric starter, 24V, 5.5kW
Service	Oil change interval 600 operating hours, average TBO 18.000 operating hours
Classification	Engine according to classification requirements available => see MAN Marine Configurator

Exhaust status IMO Tier III, EU Stage V

¹ Values at rated power

² Diesel fuel according to DIN EN 590 (tolerance +5% - ISO 3046), urea solution 32,5% according to ISO 22241 (tolerance +3%)

³ Values on propeller curve

D2676LE487

A - overall width.....	986 mm
B - overall length.....	1795 mm
C - overall height.....	1096 mm
D - above crank shaft.....	674 mm
E - length to flywheel.....	1527 mm
Engine weight, dry.....	1251 kg
(depending on the scope of supply)	

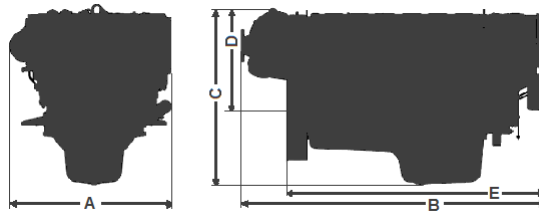

Combustion parameters ¹

Intake air temperature (max)	45 °C
Intake air vacuum (min/max)	30/60 mbar
Intake air volume flow	1405 m ³ /h
Exhaust gas temperature	430 °C
Exhaust gas volume flow	3370 m ³ /h
Exhaust gas mass flow	1650 kg/h
Exhaust back pressure (min/max) downstream of SCR catalyst	20/80 mbar

Heat balance ¹

Exhaust gas heat	190 kW
Cooling water heat	140 kW
Intercooler heat	60 kW
Radiation heat	26 kW

Noise emission (sound power) ¹

Engine surface noise (Lwa)	111,7 dB(A)
Free exhaust noise (Lwa)	92,6 dB(A)

Specific consumption²

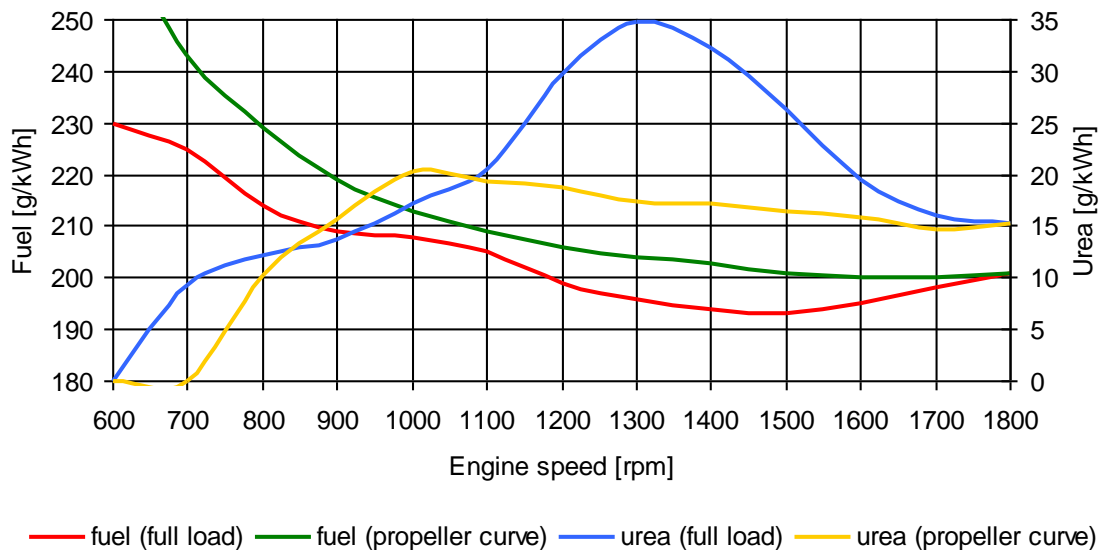

< The rated power is based on reference conditions according to ISO 3046-1 (2002) >

< Intake air temperature, max. 45°C | sea water temperature, max. 32°C >

< Barometric pressure 1000 mbar | air humidity 60% >

< Exponent for propeller curve 3 >

< Engine specifications are subjected to change without prior notice >

¹ Values at rated power

² Diesel fuel according to DIN EN 590 (tolerance +5% - ISO 3046), urea solution 32,5% according to ISO 22241 (tolerance +3%)

³ Values on propeller curve